



AKRAPOVIC SLIP-ON & SLIP-ON STREET LEGAL EXHAUST SYSTEM for the KAWASAKI Z1000 (2007- 2009)

Congratulations on purchasing an Akrapovič exhaust system. Please read these installation instructions carefully. If you have any trouble installing the system please contact your authorized dealer!

IMPORTANT INFORMATION

Exclusion of Certain Liability

1. The manufacturer, importer or dealer shall not be liable for any incidental damage including personal injury or any other damages caused by improper installation or operation of the Akrapovič exhaust system. When installing the Akrapovič exhaust system be careful that the exhaust system does not touch other parts sensitive to high temperature.
2. Akrapovič makes no representation or warranties with regard to damage caused by the improper installation, use and maintenance of the Akrapovič exhaust system. The warranty is limited to defects recognized by our technical department and to normal use, and excludes items subject to normal wear (gaskets and damping wool). The guarantee is void in case of accident, modification, improper or competition use.
3. Do not attempt to install the Akrapovič exhaust system on a motorcycle for which it was not made or tested by Akrapovič.
4. When the exhaust system gets very hot during operation, be careful not to burn yourself on the exhaust system or parts which are in direct contact with it, even when the motor is not running. Also protect other people, especially children, from the injuries mentioned above.
5. In some cases Akrapovič exhaust system kits contain chemical products (ceramic anti-seizing grease; bolt sealant). Handle with care, do not inhale or swallow. Avoid excessive contact with skin, eyes or mucous membranes. Keep out of reach of children.
6. Technical specifications of Akrapovič exhaust systems and related products subject to change without notice.

Trademarks

The Akrapovic Exhaust System Technology logo is a registered trademark of Akrapovič d.d.

Akrapovic website

Information about Akrapovic exhaust systems and related products is available on the Akrapovic website at:

<http://www.akrapovic.com/>

Copyright

No part of the Akrapovič exhaust system or its documentation may be reproduced or distributed in any form or by any means without the prior written authorization of the Akrapovič company.

© Akrapovič, d.d. All rights reserved.

Symbols

The following symbols are used throughout these installation instructions:



USE BOLT SEALANT; Apply 3 to 4 small drops of bolt sealant onto the cleaned and degreased threads before tightening bolts. **WARNING! Avoid contact with skin, eyes and mucous membranes. Do not inhale fumes. Keep out of the reach of children.**



USE ANTI-SEIZING GREASE (white tube); Prevents seizing, corrosion and excessive wear between the titanium components of your exhaust system. **WARNING! Avoid eye contact. Avoid excessive skin contact. Keep out of the reach of children.**



USE ANTI-SEIZE LEAD-FREE COPPER PASTE (black tube); Provides trouble-free and long-lasting protection against seizing, corrosion and rusting of bolts, threaded ends, nuts, joints, etc. Also protects against vibration, wear and impact. **WARNING! Avoid eye contact. Avoid excessive skin contact. Keep out of the reach of children.**

INSTALLATION INSTRUCTIONS

 BEFORE INSTALLING CHECK SCHEMATIC OF THE EXHAUST SYSTEM!

 IF ANY ITEMS IN THE AKRAPOVIC EXHAUST SYSTEM PACKAGE ARE MISSING PLEASE CONTACT YOUR AUTHORIZED DEALER. KEEP THE SCHEMATIC FOR FUTURE REFERENCE.

 THESE INSTALLATION INSTRUCTIONS MUST BE READ CAREFULLY IN ORDER TO ENSURE PROPER INSTALLATION AND OPERATION OF THE AKRAPOVIC EXHAUST SYSTEM.

 THE EXHAUST SYSTEM CAN BE EXTREMELY HOT. ALLOW THE MOTORCYCLE TO COOL DOWN BEFORE BEGINNING INSTALLATION.

 WE ADVISE YOU TO LEAVE INSTALLATION TO A QUALIFIED SERVICEMAN. IMPROPER INSTALLATION MAY RESULT IN A SHORTER LIFETIME OF THE EXHAUST SYSTEM AND/OR DAMAGE TO THE MOTORCYCLE.

 T-handle 10 mm wrench
T-handle 14 mm wrench
T-handle 3 mm three hexagon key wrench
T-handle 4 mm three hexagon key wrench
Combination 10 mm wrench
Combination 17 mm wrench
Screwdriver for headless slotted screws
Spring puller

REMOVAL OF STOCK EXHAUST SYSTEM:

1. Put the motorcycle on a side stand, we recommend a racing stand. Make sure, that surface is solid and flat.
2. Unscrew the cables from the exhaust valve on the right side muffler (**Figure 1, 2**). Unscrew the injection cover and fuel-tank side panel (**Figure 3, 4**). Remove the safety pin from the exhaust valve servo motor and completely remove the cables from the motorcycle (**Figure 5, 6**). **WARNING: do not turn the servo motor wheel with force (only by ignition key switching) or the servo motor could be damaged! WARNING: do not disconnect the electrical installation of the servo motor!** Reinstall the injection cover and fuel-tank side panel in the reverse order from the order in which they were removed.



Figure 1



Figure 2



Figure 3



Figure 4



Figure 5



Figure 6

3. Unscrew the bolts from the metal clamp at the muffler - collector joint and muffler sub-frame brackets. Remove the muffler. Perform the process on both sides of the motorcycle (Figure 7, 8, 9).



Figure 7



Figure 8



Figure 9

INSTALLATION OF THE AKRAPOVIČ SLIP-ON EXHAUST SYSTEM:

1. Change both stock graphite gaskets in collector with Akrapovič graphite gaskets and correctly install clamps with hooks for springs – warning: the clamps with hooks are not symmetrical (left; right) – check photos for correct installation (Figure 10, 11, 12, 13).



Figure 10

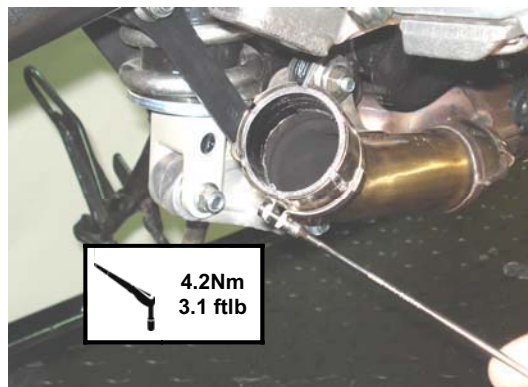

Figure 11



Figure 12

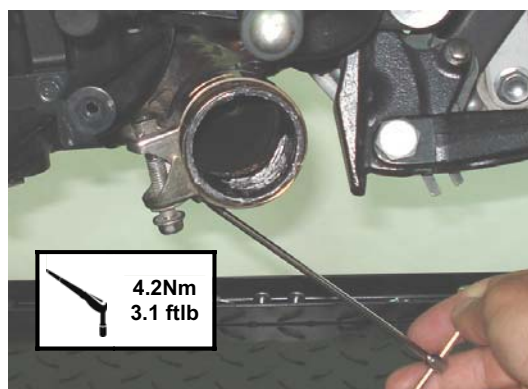

Figure 13

2. Slide both link pipes into the stock collector and attach the springs; **WARNING:** make sure, that springs pull the link pipe all the way onto the collector– use rubber mallet if necessary to tap the connections into place! (Figure 14, 15, 16, 17).



Figure 14



Figure 15



Figure 16



Figure 17

3. For SLIP-ON STREET LEGAL ONLY: Insert the catalytic converters into the link-pipes as shown (Figure 18, 19).



Figure 18



Figure 19

4. Position the mufflers correctly and slide them onto the outlet side of the link pipes (Figure 20). Correctly position the carbon-fiber clamps and slide them onto the mufflers - bear in mind the **left offset** of the carbon-fiber clamp viewed from the rear for right side and the **right offset** for the left side. **WARNING: open the clamps slightly wider than the diameter of the outer sleeves of the mufflers – do not scrape them along the mufflers outer sleeve! (Figure 21).** Hand tighten the carbon-fiber clamps onto the stock brackets. Position and attach the springs **WARNING: make sure, that springs pull the muffler all the way onto the link pipe – use rubber mallet if necessary to tap the connections into place! (Figure 22).** Tighten the stock bolts on the carbon-fiber clamps/stock muffler brackets joints (Figure 23). Make sure the link pipe or muffler are not touching the frame and other parts. Tighten the stock metal clamps at link-pipes / stock collector joints (Figure 24, 25).



Figure 20



Figure 21



Figure 22

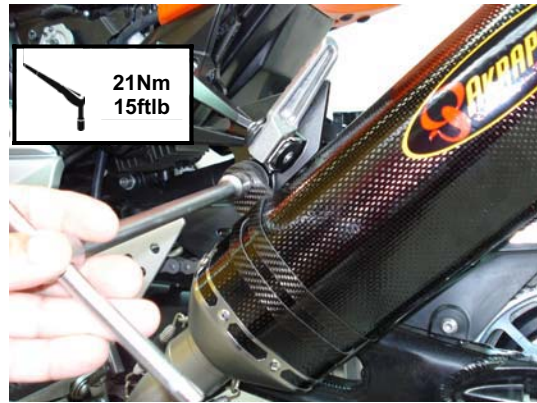

Figure 23

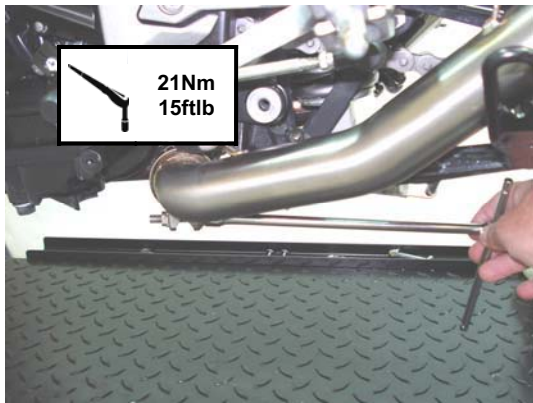

Figure 24

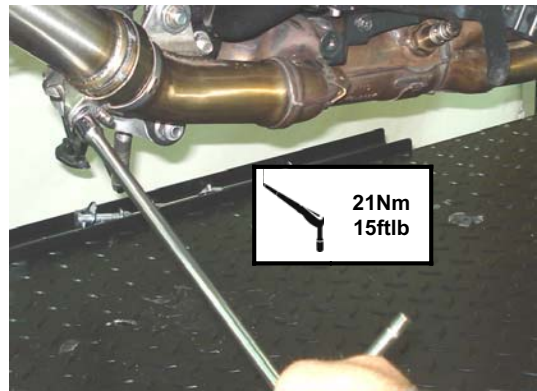

Figure 25

Final installation:

1. Clean grease spots:

- a. Muffler – carbon-fiber outer sleeve: use a soft dry cloth.
- b. Muffler – titanium outer sleeve: use a soft cloth sprayed with a multi-purpose spray lubricant (WD-40 or equivalent).
- c. Muffler – carbon-fiber outlet cap: use a soft dry cloth.
- d. Stainless steel link pipes: use a soft cloth sprayed with a contact cleaner, then wipe with a soft dry cloth

Cleaning will prevent spots from burning onto the surface. Do not use aggressive chemical cleaners, because they can damage the sticker.

Position of the correctly installed Akrapovič SLIP-ON system (Figure 26).



Figure 26

2. Check the operation of the brakes and suspension. Make sure all the bolts are sufficiently tightened. In case the exhaust system touches the cowling or other parts repeat the adjustment of the exhaust system or contact your authorized dealer.

! IT IS NORMAL IF WHITE SMOKE COMES OUT OF THE MUFFLER ON FIRST OPERATION.

! DO NOT STAND BEHIND THE MUFFLER ON FIRST OPERATION.

! DO NOT USE AUTOMOTIVE WHEEL CLEANERS OR ANY CLEANING PRODUCTS WHICH CONTAIN ACIDIC ADDITIVES TO CLEAN AKRAPOVIČ EXHAUST SYSTEMS.

MAINTENANCE OF THE AKRAPOVIČ EXHAUST SYSTEM

1. Clean the titanium exhaust components with a multi-purpose spray lubricant (WD-40 or equivalent), carbon fiber exhaust components with soft and dry cloth and stainless steel components with soft cloth sprayed with contact cleaner, then wipe with soft and dry cloth. Do not use aggressive chemical cleaners, because they can damage the sticker. A change in the color of the exhaust system is normal due to the high temperatures.
2. The wearing out of the muffler silencing material depends on the type of the engine and riding style. Contact your dealer/serviceman if visible changes appear on muffler's outer sleeve or the noise level is increased.
3. Periodically make sure all the bolts and springs are sufficiently tight.

KAWASAKI Z1000, Slip on, model year: 2007 - 2009

Product code: S-K10SO3-ZC
S-K10SO3-ZT

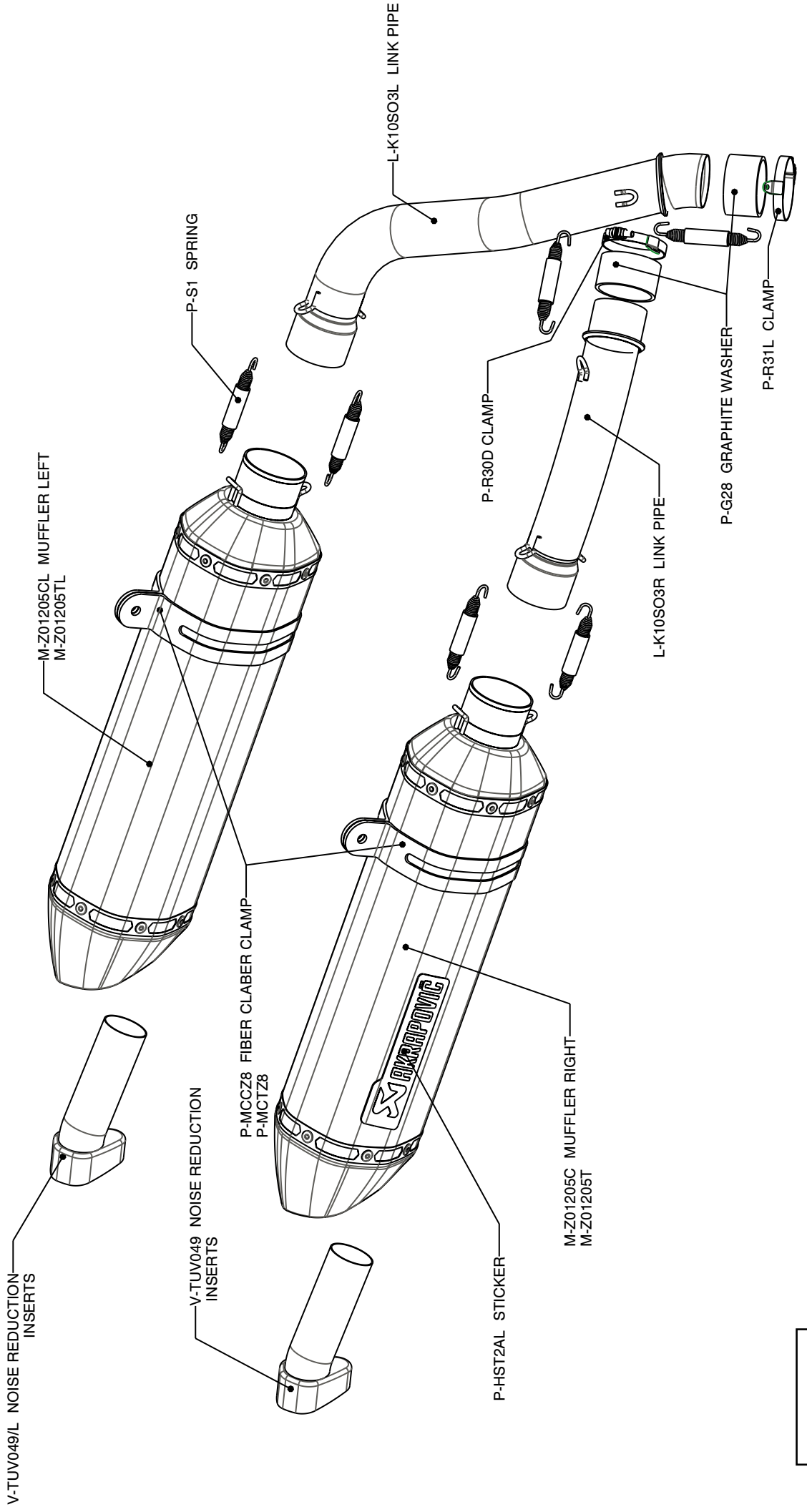

KAWASAKI Z1000, Slip on, Street legal, model year: 2007-2009

Product code: S-K10SO3C-HZC
S-K10SO3C-HZT

