



## AKRAPOVIC STREET LEGAL SLIP-ON EXHAUST SYSTEM for the BMW G650Xmoto, Xchallenge, Xcountry (2007- 2009)

Congratulations on purchasing an Akrapovic exhaust system. Please read these installation instructions carefully. If you have any trouble installing the system please contact your authorized dealer!

### IMPORTANT INFORMATION

#### Exclusion of Certain Liability

1. The manufacturer, importer or dealer shall not be liable for any incidental damage including personal injury or any other damages caused by improper installation or operation of the Akrapovic exhaust system. When installing the Akrapovic exhaust system be careful that the exhaust system does not touch other parts sensitive to high temperature.
2. Akrapovic makes no representation or warranties with regard to damage caused by the improper installation, use and maintenance of the Akrapovic exhaust system. The warranty is limited to defects recognized by our technical department and to normal use, and excludes items subject to normal wear (gaskets and damping wool). The guarantee is void in case of accident, modification, improper or competition use.
3. Do not attempt to install the Akrapovic exhaust system on a motorcycle for which it was not made or tested by Akrapovic.
4. When the exhaust system gets very hot during operation, be careful not to burn yourself on the exhaust system or parts which are in direct contact with it, even when the motor is not running. Also protect other people, especially children, from the injuries mentioned above.
5. In some cases Akrapovic exhaust system kits contain chemical products (ceramic anti-seizing grease; bolt sealant). Handle with care, do not inhale or swallow. Avoid excessive contact with skin, eyes or mucous membranes. Keep out of reach of children.
6. Technical specifications of Akrapovic exhaust systems and related products subject to change without notice.

#### Trademarks

The Akrapovic Exhaust System Technology logo is a registered trademark of Akrapovic d.d.

#### Akrapovic website

Information about Akrapovic exhaust systems and related products is available on the Akrapovic website at:

<http://www.akrapovic.com/>

#### Copyright

No part of the Akrapovic exhaust system or its documentation may be reproduced or distributed in any form or by any means without the prior written authorization of the Akrapovic company.

© Akrapovic, d.d. All rights reserved.

#### Symbols

The following symbols are used throughout these installation instructions:



 **USE BOLT SEALANT;** Apply 3 to 4 small drops of bolt sealant onto the cleaned and degreased threads before tightening bolts. **WARNING! Avoid contact with skin, eyes and mucous membranes. Do not inhale fumes. Keep out of the reach of children.**

 **USE ANTI-SEIZING GREASE (white tube);** Prevents seizing, corrosion and excessive wear between the titanium components of your exhaust system. **WARNING! Avoid eye contact. Avoid excessive skin contact. Keep out of the reach of children.**

 **USE ANTI-SEIZE LEAD-FREE COPPER PASTE (black tube);** Provides trouble-free and long-lasting protection against seizing, corrosion and rusting of bolts, threaded ends, nuts, joints, etc. Also protects against vibration, wear and impact. **WARNING! Avoid eye contact. Avoid excessive skin contact. Keep out of the reach of children.**

## INSTALLATION INSTRUCTIONS

 BEFORE INSTALLING CHECK SCHEMATIC OF THE EXHAUST SYSTEM!

! IF ANY ITEMS IN THE AKRAPOVIC EXHAUST SYSTEM PACKAGE ARE MISSING PLEASE CONTACT YOUR AUTHORIZED DEALER. KEEP THE SCHEMATIC FOR FUTURE REFERENCE.

! THESE INSTALLATION INSTRUCTIONS MUST BE READ CAREFULLY IN ORDER TO ENSURE PROPER INSTALLATION AND OPERATION OF THE AKRAPOVIC EXHAUST SYSTEM.

! THE EXHAUST SYSTEM CAN BE EXTREMELY HOT. ALLOW THE MOTORCYCLE TO COOL DOWN BEFORE BEGINNING INSTALLATION.

 WE ADVISE YOU TO LEAVE INSTALLATION TO A QUALIFIED SERVICEMAN. IMPROPER INSTALLATION MAY RESULT IN A SHORTER LIFETIME OF THE EXHAUST SYSTEM AND/OR DAMAGE TO THE MOTORCYCLE.

 T-handle 8mm wrench  
T-handle 5mm three hexagon key wrench  
T-handle 6mm three hexagon key wrench  
Torx wrench T30  
Spring puller

## REMOVAL OF STOCK EXHAUST SYSTEM

1. Put the motorcycle on a side stand, we recommend a racing stand. Make sure, that surface is solid and flat.
2. Unscrew the **bolt A** from the metal clamp at the link pipe – header tube joint (**Figure 1**).

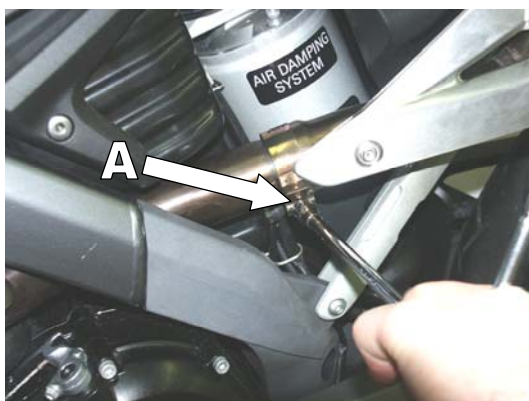

Figure 1

3. Unscrew and remove the **bolt B** from the muffler metal bracket (**Figure 2**).



Figure 2

4. Remove the muffler (Figure 3).



Figure 3

### INSTALLATION OF THE AKRAPOVIC SLIP-ON EXHAUST SYSTEM

#### installing the carbon-fiber heat shields:

1. Correctly position and install the Akrapovic carbon-fiber heat shields; use the bolts, washer and spacers supplied in the Akrapovic kit. Install the heat shields onto the link-pipe (10mm Ak. Bolts) and muffler (16mm Ak. Bolts); make sure the heat-resistant distance washers and bolts are correctly installed (Figure 8, 9, 10).



Figure 8

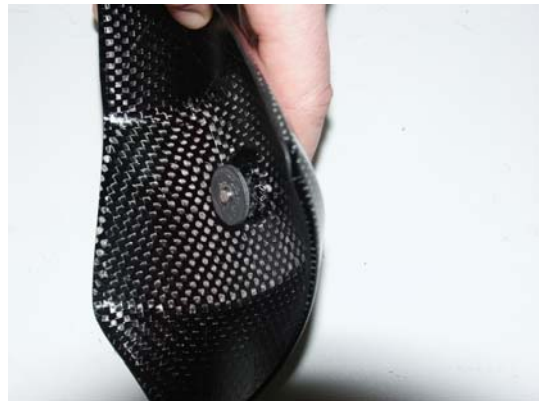

Figure 9

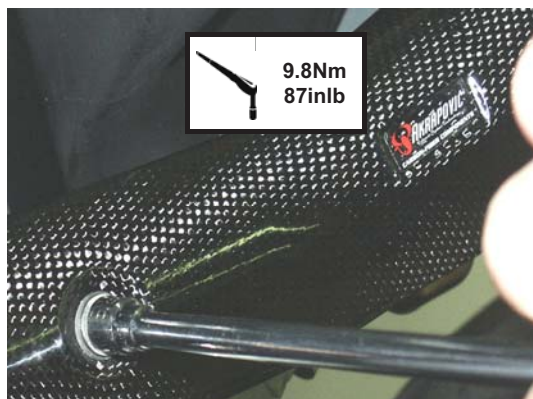
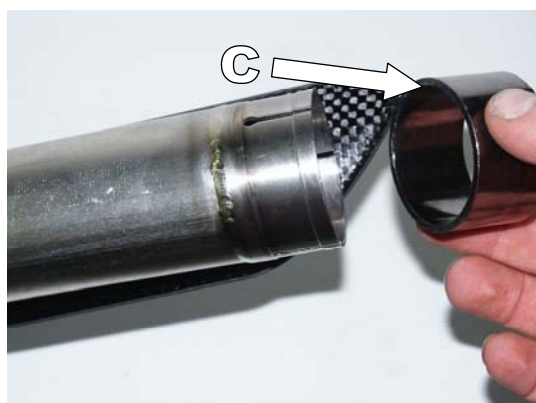

Figure 10

**installing the link pipe with welded muffler:**

1. Install the **graphite sleeve gasket C** into the inlet of the link pipe (**Figure 11**).
2. Coat the bolt and interior of the metal clamp with Akrapovic anti-seize lead-free copper paste (black tube) and correctly install the metal clamp onto the link pipe (**Figure 12**).



*Figure 11*

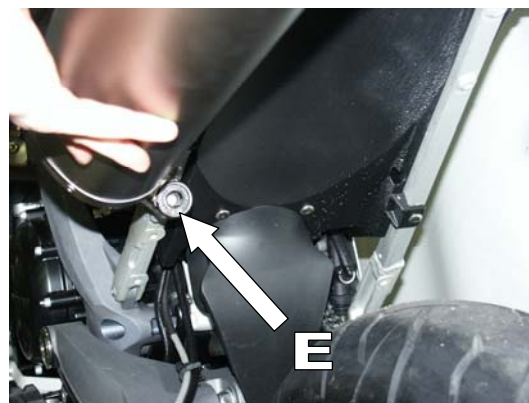

*Figure 12*

3. Correctly position the muffler with the link pipe and slide it onto the header tube; make sure that **link-pipe bracket E** slides correctly onto the sub-frame **bracket F** (**Figure 13, 14**).



*Figure 13*



*Figure 14*

4. Attach the muffler bracket to the stock chassis hanging bracket – use stock bolt, washer and spacer. Tighten the metal clamp on the link-pipe – header tube connection (**Figure 15, 16**).



*Figure 15*



*Figure 16*



5. Make sure the muffler, link pipe and header tube are not touching the engine or frame. Clean the surface on the inner side of the muffler cover stock side panel; use a soft cloth sprayed with a contact cleaner. Remove the adhesive liner from bonding tape of **rubber spacers G**. Align the **rubber spacers G** and press them firmly for 30 seconds on the cleaned stock panel (**Figure 17, 18**). **Wait for one hour before use!**

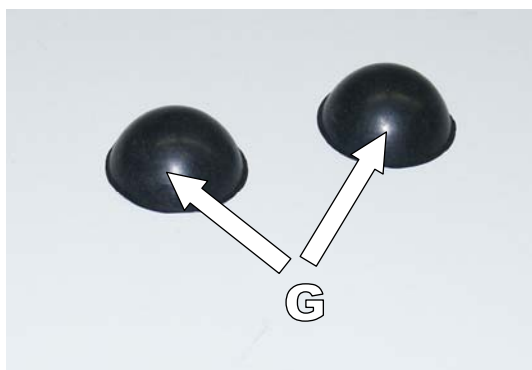

Figure 17



Figure 18

**Final installation:**

1. Clean grease spots:
  - a. Muffler – titanium outer sleeve: use a soft cloth sprayed with a multi-purpose spray lubricant (WD-40 or equivalent).
  - b. SLIP-ON - titanium link pipe: use a soft cloth sprayed with a multi-purpose spray lubricant (WD-40 or equivalent). Cleaning will prevent spots from burning onto the surface. Do not use aggressive chemical cleaners, because they can damage the sticker.
2. **WARNING: after running engine for 30 minutes, tighten the bolts on the Akrapovic carbon-fiber heat shields!**

3. **Check the operation of the brakes and suspension. Make sure all the bolts are sufficiently tightened. In case the exhaust system touches the cowling or other parts repeat the adjustment of the exhaust system or contact your authorized dealer.**

- |  |
|--|
| <p><b>! IT IS NORMAL IF WHITE SMOKE COMES OUT OF THE MUFFLER ON FIRST OPERATION.</b></p>   |
| <p><b>! DO NOT STAND BEHIND THE MUFFLER ON FIRST OPERATION.</b></p>  |
| <p><b>! DO NOT USE AUTOMOTIVE WHEEL CLEANERS OR ANY CLEANING PRODUCTS WHICH CONTAIN ACIDIC ADDITIVES TO CLEAN AKRAPOVIC EXHAUST SYSTEMS.</b></p> |

**MAINTENANCE OF THE AKRAPOVIC EXHAUST SYSTEM**

1. Clean the titanium exhaust components with a multi-purpose spray lubricant (WD-40 or equivalent ), carbon fiber exhaust components with soft and dry cloth and stainless steel components with soft cloth sprayed with contact cleaner, then wipe with soft and dry cloth. Do not use aggressive chemical cleaners, because they can damage the sticker. A change in the color of the exhaust system is normal due to the high temperatures.
2. The wearing out of the muffler silencing material depends on the type of the motor and riding style. Contact your dealer/serviceman if visible changes appear on muffler's outer sleeve or the noise level is increased.
3. Periodically make sure all the bolts and springs are sufficiently tight.

# BMW G650 X / SLIP ON Exhaust System, model year: 2007-2009/ OPEN

Product code: S-B6SO1C-LT

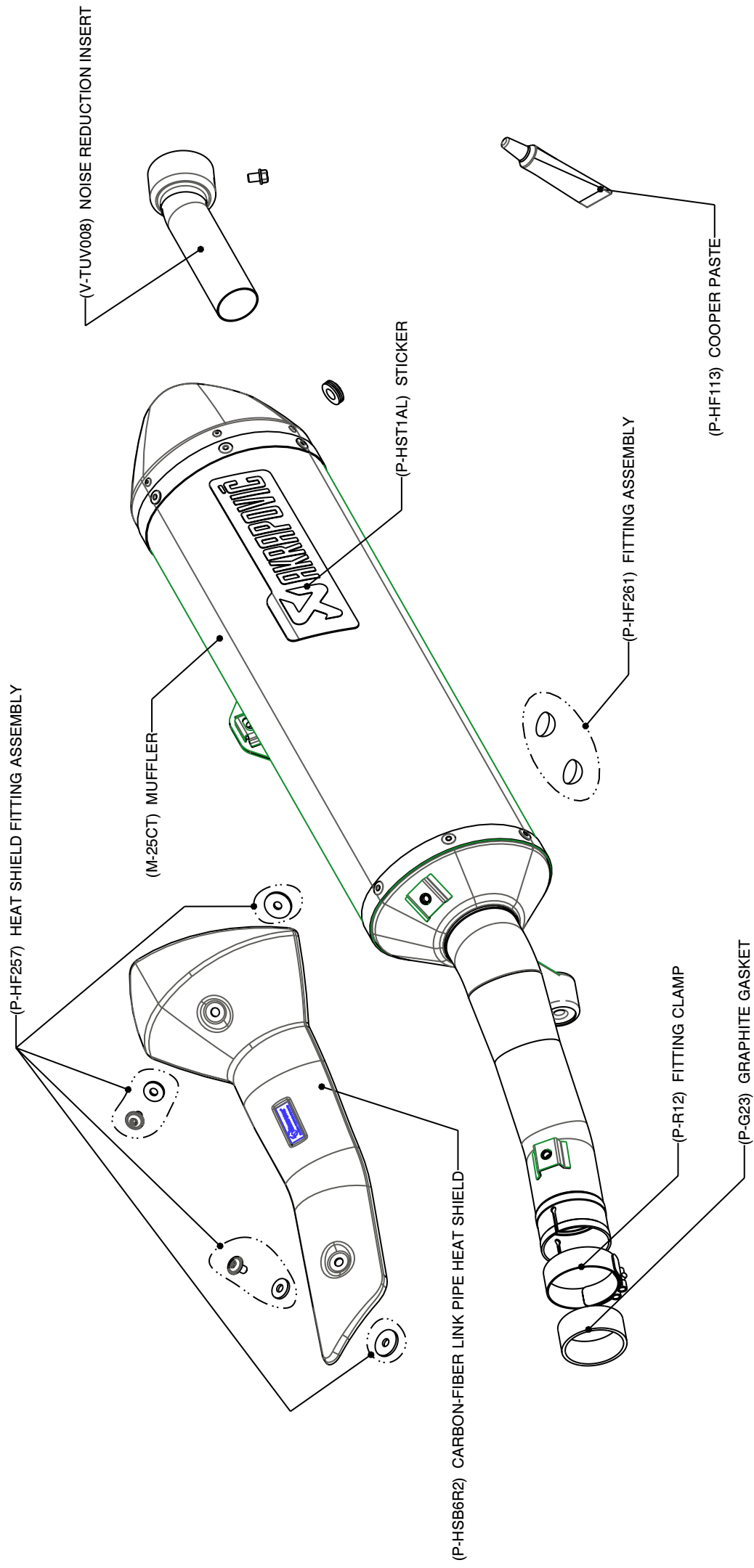

BMW G650 X/ SLIP ON Exhaust System, model year: 2007 - 2009/ STREET LEGAL

Product code: S-B6SO1C-HLT

